

Vacuum Ribbon Blender Mixer (RBM)

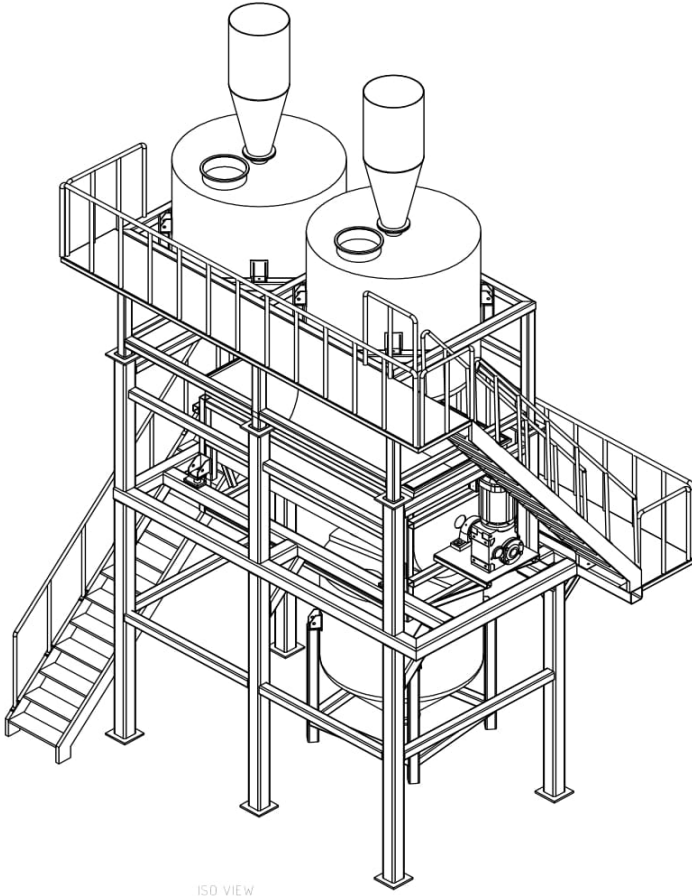

ISD VIEW

Figure 1 : Ribbon Blender Mixer design with vacuum feeders on top eliminating "powder" pollution and screw mixer at the bottom for ease of packing.



Figure 2 : Double helical ribbon design with Teflon scraper



Figure 3 : Ribbon Blender with vacuum feeders on top.

Multimix Vacuum Ribbon Blender Mixer (RBM) Series is mainly designed for the blending of dry powders products such as spices, cosmetic compact powder, detergent, cleaning chemicals, coffee powders etc. A special liquid spraying system (LSS) can also be added when incorporating liquid phase in the powder. This series can also be enhanced with vacuum design in order to eliminate "powder" pollution when powders need to be incorporated into the mixing chamber. The vacuum mechanism sucks the powder into mixing chamber, thus effectively preventing the powder which is light in nature from dispersing in the surrounding air leading to powder pollution usually seen in conventional method of direct pouring of powders into the mixing chamber.

Main Advantages

- Robust solution for dry, repeatable mixing and blending
- Double ribbon design with Teflon scraper for homogenous contra mixing and shorter batch time
- Elimination of dusty environment
- Electrical lid lifting system for better ergonomics
- Easy clean up, maintenance and spare parts change
- Vacuum design prevents oxidation during mixing
- Explosion proof motor for utmost safety
- GMP and sanitary design compliant

VACUUM RIBBON BLENDER MIXER

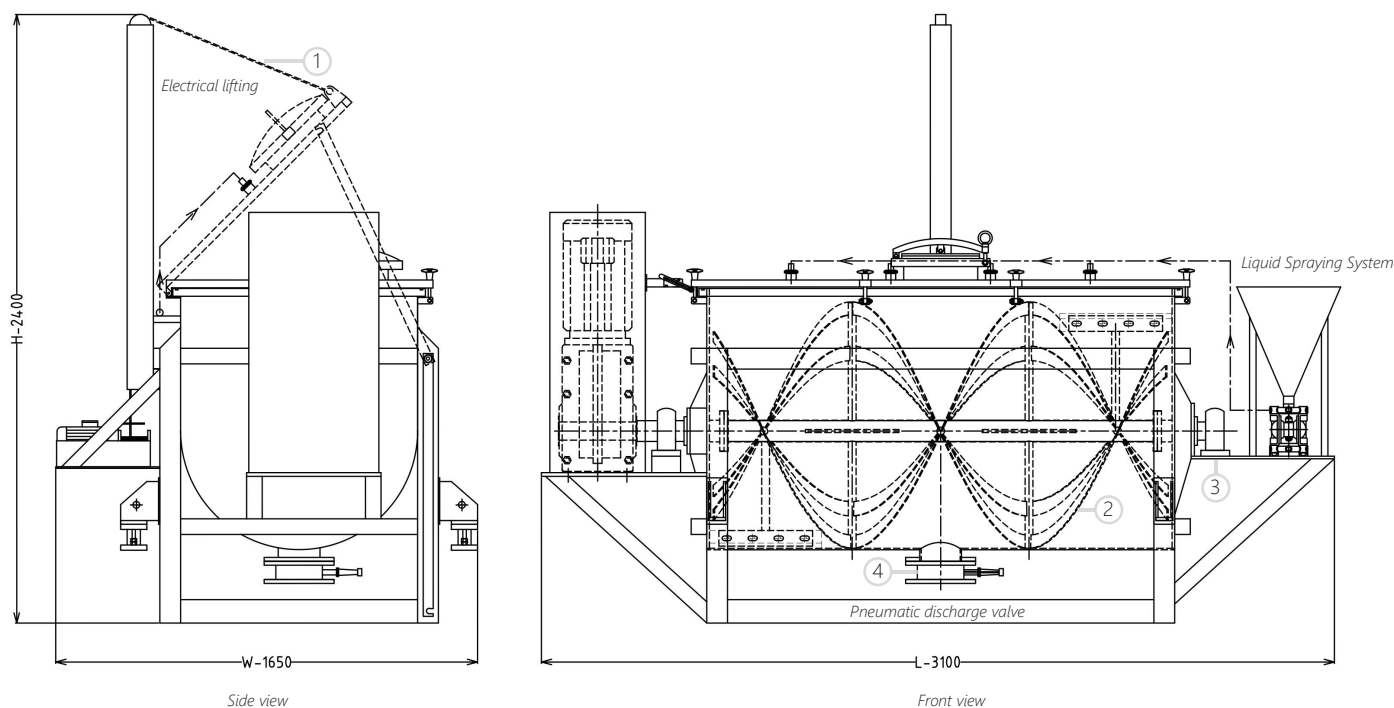

1. Safe working environment

The cover is not only fitted with electrical lifting system but also with a limit switch to detect if the cover is opened. If yes, the machine operation stops automatically ensuring safety for the workers at all time.

2. Efficient and homogenous dry mixing

Within the U-shaped horizontal trough, the double helical shaped ribbon comes with Teflon scrapper designed to mix and blend the materials in opposite direction as they rotate, shortening batch times and improving blend quality.

3. Ease of cleaning

Both bearings are sealed from outside which means that cleaning and changing the bearings can be done easily externaly without contaminating the powders inside.

4. Maximum product yield

The center discharge design ensures that most of the materials are discharged fully with minimal loss. Depending on the application (dry/wet), special discharge valves e.g. pneumatic/electrical control valve are used for ease of opening and to prevent material leakage. Special screw mixer can be additionally configured for ease of packing.

RBM

Power supply	Three phase, 380V/415V, 50/60Hz
Impeller design	Double helical ribbon with Teflon scraper
Clearance	8 – 10 mm
Seal	Gland packing with Teflon bush
Wetted parts material	Food and medical grade stainless steel 316L
Discharge valve	Butterfly with pneumatic mechanism

Model	RBM 200	RBM 400	RBM 1200	RBM 2100	RBM 3200	RBM 4000	RBM 6000	RBM 10000
Mixing capacity (H ₂ O)	200 Litre	400 Litre	1200 Litre	2100 Litre	3200 Litre	4000 Litre	6000 Litre	10000 Litre
Motor in HP (equivalent kW)	3HP (2.2kW)	5HP (3.7kW)	10HP (7.5kW)	15HP (11.2kW)	20HP (15kW)	25HP (18.5kW)	40HP (30kW)	50HP (37.5kW)
Speed range (variable speed electronically controlled)	50 rpm	50 rpm	50 rpm	50 rpm	50 rpm	25 rpm	20 rpm	15 rpm
Trough	Length	970 mm	1220 mm	1980 mm	2440 mm	3050 mm	3050 mm	3660 mm
	Width	430 mm	540 mm	760 mm	910 mm	1020 mm	1110 mm	1380 mm
	Depth	530 mm	640 mm	870 mm	1010 mm	1120 mm	1220 mm	1480 mm

Add-Ons (optional)

- A. Liquid spraying system (LSS)
- B. Vacuum feeders for ingredients input
- C. Vacuum/pressure design for vacuum mixing
- D. Jacketed vessel for heating/cooling
- E. Mobile design e.g. caster wheels
- F. Safety features e.g. sieve & limit switch
- G. Motorized lifting system for cover
- H. Panel control with frequency inverter
- I. Clean In Place (CIP) design
- J. Weighing system
- K. Explosion proof motor & remote control station

CKL Multimix (M) Sdn. Bhd. (293804-M)
No 21 & 23, Jalan Industri Mas 12,
Taman Mas Sepang, 47100 Puchong,
Selangor, Malaysia.

Tel : +60 (0) 3 8051 3940
Fax : +60 (0) 3 8051 4867
Email : chong.cklmultimix@gmail.com

For further enquiries, please contact us or our authorised distributors and agents.

Multimix
www.multimix.com.my